

# A Novel Type of Wound Optical Cable

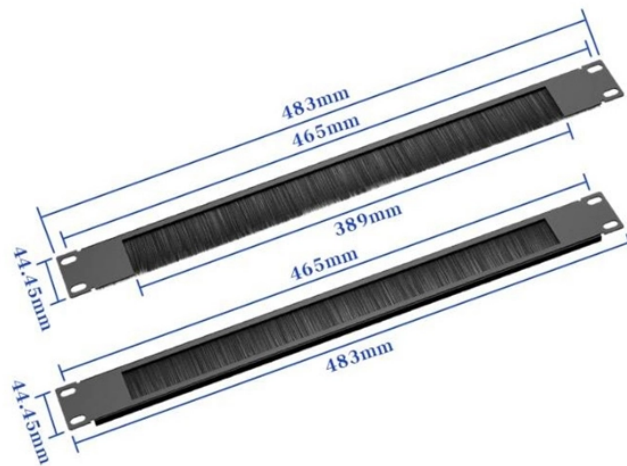

## Overview

Hybrid Fiber Optic Cable for Strain Sensing in Brittle Media This research presents a novel sensing cable design for use in brittle installation media where physical point-fixation is not possible due to accessibility limitations, such as within deep boreholes. It is one of the few installations of this kind in Germany. Optical attached cable (OPAC) is a type of fibre-optic cable that is installed by being attached to a host conductor along overhead power lines. The attachment system varies and can include wrapping, lashing or clipping the fibre-optic cable. A densely-wound optical fiber type ultra-sensitive oil well sensing optical cable, comprising a tensile reinforcing member (6), an outer sheath (1), a curing layer (2), a sensing optical fiber (3), and an elastic sensitivity-enhancing structure (4). DAS systems with straight fiber optic cables have high sensitivity towards P-waves traveling along the fiber, so DAS is most widely used for Vertical Seismic Profile (VSP) surveys, where the cable is. Armored fiber optic cables are designed to protect delicate optical fibers from physical damage while maintaining high transmission performance. With a durable protective layer, they are ideal for harsh or high-traffic environments. This article explains what armored fiber cables are, their key.

gy applications.

## A Novel Type of Wound Optical Cable



In this study, we propose a new type of HWC (Helical Wound Optical Cable) based distributed acoustic sensing technology for onshore seismic acquisition. In addition, we present the results of relevant ...



In this work, a novel hybrid fiber optic cable is proposed to overcome the limitations of distributed fiber optic sensing for crack detection and monitoring in brittle media.



Although lashed cable systems and clipped cable systems have been investigated as a means of attaching optical fibre cables to overhead power lines, wrapped cables were the first type to be ...



Learn different types of armored fiber optic cable, including steel wire, corrugated, and indoor armored cables. Complete guide for telecom and industrial use.



Investigation of the effects of surrounding media on the distributed acoustic sensing of a helically wound fibre-optic cable with application to the New Afton deposit, British Columbia



seismic surveys offers multiple advantages over more traditional sensors (Bakulin et al., 2020). However, to use horizontal fiber optic cables only on the surface (or slightly buried under the surface ...



Armored fiber optic cables are designed to protect delicate optical fibers from physical damage while maintaining high transmission performance. With a durable protective layer, they are ...



The invention relates to the technical field of sensing optical cables, in particular to a densely wound optical fiber type ultra-sensitive oil well sensing optical cable.



Although lashed cable systems and clipped cable systems have been investigated as a means of attaching optical fibre cables to overhead power lines, wrapped cables were the first type to be ...



Non-metallic armoured optoelectronic cable winch system (NAOCWS) is used for deployment, retrieval and towing of subsea equipment while transmitting electrical power and optical ...



Learn different types of armored fiber optic cable, including steel wire, corrugated, and indoor armored cables. Complete guide for telecom and ...

## Contact Us

For more information, pricing, or custom solutions, please contact us:

Website: <https://indzawo.co.za>

Email: [sales@indzawo.co.za](mailto:sales@indzawo.co.za)

Phone: +27 71 296 8473

Address: 22 Quantum Street, Midrand, 1685, Gauteng, South Africa

This document is for informational purposes only. Specifications subject to change without notice.

