

PoF Industrial Switches

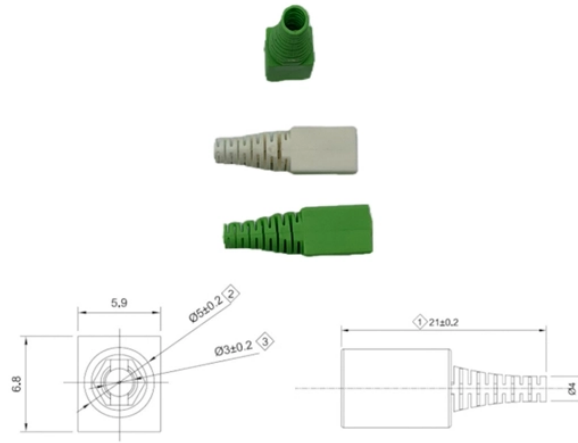

PoF Industrial Switches



IGS-6325-24UP4X Industrial L3 24-Port
10/100/1000T 802.3bt PoE + 4-Port 10G SFP+
Managed Ethernet Switch



Ethernet Media Converters and POF Network
Switches that Provide a Quick and Inexpensive
Way to Bring POF into a Home or Business
Network.



The FL SWITCH IRT switches use built-in ERTEC
(Enhanced Real Time Ethernet Controller)
technology to forward PROFINET data packets as
fast as possible using the cut-through method.



Rugged, yet easy to use, Perle has over 734
models of Ethernet switches that feature Industrial
Protocol Management support, superior reliability,
advanced security, network redundancy, and easy
...

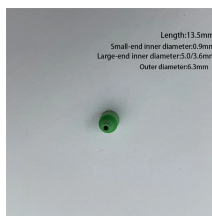

FS PoE industrial switches support 60W PoE++,
delivering reliable power and data for surveillance,
IoT, automation, and smart city applications in
demanding environments.



These switches exhibit exceptional versatility, supporting all fiber types, including multi-mode, single-mode, Plastic Optical Fiber (POF), and Hard Clad Silica (HCS) or Polymer Clad Fiber (PCF). This ...



The FL SWITCH IRT are four-port switches for PROFINET applications. The ERTEC 400 switch architecture ensures optimum integration and diagnostics of infrastructure components in PROFINET ...



When PoE switches are designed for use in harsh or extreme environmental conditions, such as industrial automation, military, marine, mining, oil-and-gas, or railway applications, the device may be ...

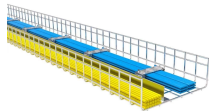

PoE switches built for industrial environments are specifically designed to be capable of withstanding extreme temperatures, humidity and electrical interference. This makes them ideal for harsh ...



The product series e-light REG consists of industrial basic switches that support Fast Ethernet. Their housing is build according to DIN 43880 and thus they can flexibly be mounted in either switch ...

Contact Us

For more information, pricing, or custom solutions, please contact us:

Website: <https://indzawo.co.za>

Email: sales@indzawo.co.za

Phone: +27 71 296 8473

Address: 22 Quantum Street, Midrand, 1685, Gauteng, South Africa

This document is for informational purposes only. Specifications subject to change without notice.

