

Portuguese Explosion-proof Distribution Box Manufacturing Company

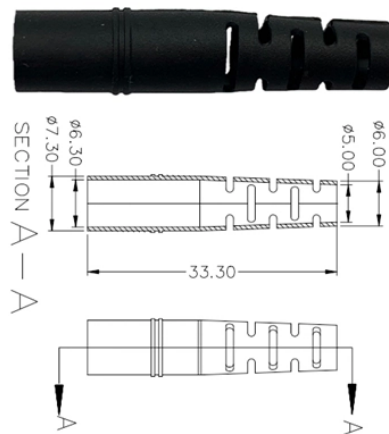





Overview

27 suppliers for portugal-explosion-proof-distribution-box-factory-direct-sales Manufacturer/Producer ✓ Find wholesalers and contact them directly ✓ B2B marketplace ► Find companies now! 27 suppliers for portugal-explosion-proof-distribution-box-factory-direct-sales Manufacturer/Producer ✓ Find wholesalers and contact them directly ✓ B2B marketplace ► Find companies now! Custom Boxes Azz UK is a professional packaging company in the United Kingdom specializing in bespoke packaging solutions, custom cardboard boxes, and fully branded packaging designed to help. Since 2003, we have been producing customized designs, sizes, quantities, and quality for our customers. Manufacture custom made Local Control Stations & Distribution Boxes, local control panel boards and stations, explosion protected control units, distribution. ·Flameproof enclosure (Ex db), which can be used as feed distribution equipment in control and distribution system (such as distribution box, switch box of main circuit, control box, terminal box or motor starting box etc.) Enclosure: 304 stainless steel, 316L stainless steel and Q235. ·Equipped.

Options range from Ex d (flameproof enclosure) to Ex e (increased safety) and Ex i (intrinsically safe) right through to Ex p (pressurized housing), as well as combinations of different explosion-protection types - always bearing in mind the most efficient solution for your application. BARTEC. Minmile's explosion-proof products focus on the risks of dust and flammable gas explosions in the food industry, adapting to the safety needs of the entire production process. Warom specializes in manufacturing explosion-proof.

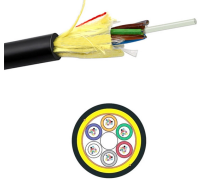
Portuguese Explosion-proof Distribution Box Manufacturing Company

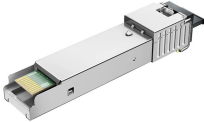
	<p>Minimally use flame-proof/intrinsically safe/dust explosion-proof technologies to block ignition sources, are compatible with Zone 1/2 gas and Zone 21/22 dust ...</p>
	<p>·Equipped with specialized hinge structure, which can prevent the flameproof joints from damage when opening and closing the box, and greatly prolong the service life of box. The boxes can be combined ...</p>
	<p>BARTEC offers one of the most extensive ranges of explosion-proof and substance-resistant components, devices, and systems for controlling, switching, and connecting for hazardous areas ...</p>
	<p>27 suppliers for portugal-explosion-proof-distribution-box-factory-direct-sales Manufacturer/Producer Find wholesalers and contact them directly B2B marketplace Find companies now!</p>
	<p>With features like sealed closures, durable construction, and advanced circuit protection, our explosion-proof distribution boxes provide peace of mind and enhance operational efficiency.</p>



Atex control stations, explosion protected control units and distribution boxes made stainless steel maritime grade AISI 316L or AISI 304L. Atex Delvalle provides a custom build facility for Hazardous ...

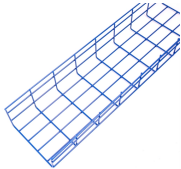

We offer bespoke, custom-made terminal boxes and terminal box combinations, as well as standard products with short delivery times. Our products are certified for installation technologies all over the ...



These are available in a range of materials including Stainless Steel, GRP & Sheet Steel from IP42 (Indoor) to IP 66 (Outdoor) Applications.



Minimise use flame-proof/intrinsically safe/dust explosion-proof technologies to block ignition sources, are compatible with Zone 1/2 gas and Zone 21/22 dust hazardous areas, and fully meet standards to ...



All explosion-proof enclosures, lighting or power distribution boxes are manufactured using the latest technologies, both mechanical and electrical, using materials able to resist in most highly corrosive ...

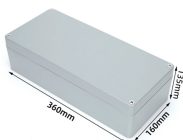

Warom specializes in manufacturing explosion-proof electrical equipment, with products covering explosion-proof lighting fixtures, explosion-proof distribution boxes, explosion-proof control ...

Contact Us

For more information, pricing, or custom solutions, please contact us:

Website: <https://indzawo.co.za>

Email: sales@indzawo.co.za

Phone: +27 71 296 8473

Address: 22 Quantum Street, Midrand, 1685, Gauteng, South Africa

This document is for informational purposes only. Specifications subject to change without notice.

