

Wiring Process Requirements for Distribution Boxes

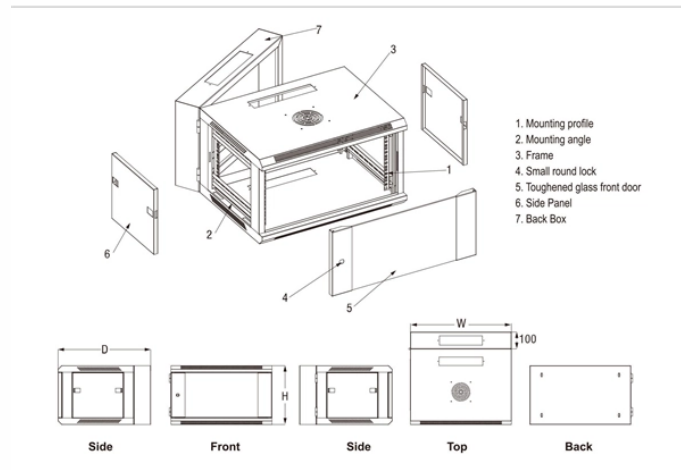

Wiring Process Requirements for Distribution Boxes



Learn how to connect a distribution box with this easy-to-follow, step-by-step guide. From tools and materials needed to common installation mistakes and solutions, this comprehensive article will ...



The document is intended to help electrical engineers and supervisors install distribution boards for electrical projects according to contract requirements and specifications.



Master the safest and most efficient circuit breaker wiring configurations. Learn about single-phase vs. three-phase setups, safety standards, and future-proof electrical planning.



Learn how to install a distribution box safely and correctly. Covers wiring, placement, standards, and expert tips for a compliant setup.

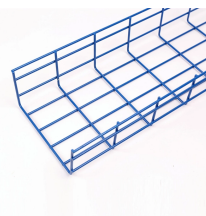

First of all, you need to have a simple understanding of the definition of a distribution box, and make it clear which kind of distribution box you want to install.



Learn how to wire a distribution box step by step! This video shows real on-site footage of electrical installation, demonstrating safe and standardized wiring methods used by professionals.



Box installation: Make sure that Distribution box has been correctly installed and fixed. Material preparation: Prepare the required circuit breakers, wires, wiring ties and other materials, and ...



Essential Guidelines for Safe and Compliant Electrical Systems. Think of your home's distribution box as the Grand Central Station of your electrical system. Just like travelers need clear pathways and ...



Master the safest and most efficient circuit breaker wiring configurations. Learn about single-phase vs. three-phase setups, safety standards, and future-proof electrical ...



Securely manage job site power. Build a compliant temporary distribution box, detailing component sizing, critical grounding, and wiring integrity.



This article provides a detailed overview of the entire process of installing a distribution box, from pre-installation preparation to post-installation maintenance, and summarizes common ...

Contact Us

For more information, pricing, or custom solutions, please contact us:

Website: <https://indzawo.co.za>

Email: sales@indzawo.co.za

Phone: +27 71 296 8473

Address: 22 Quantum Street, Midrand, 1685, Gauteng, South Africa

This document is for informational purposes only. Specifications subject to change without notice.

